

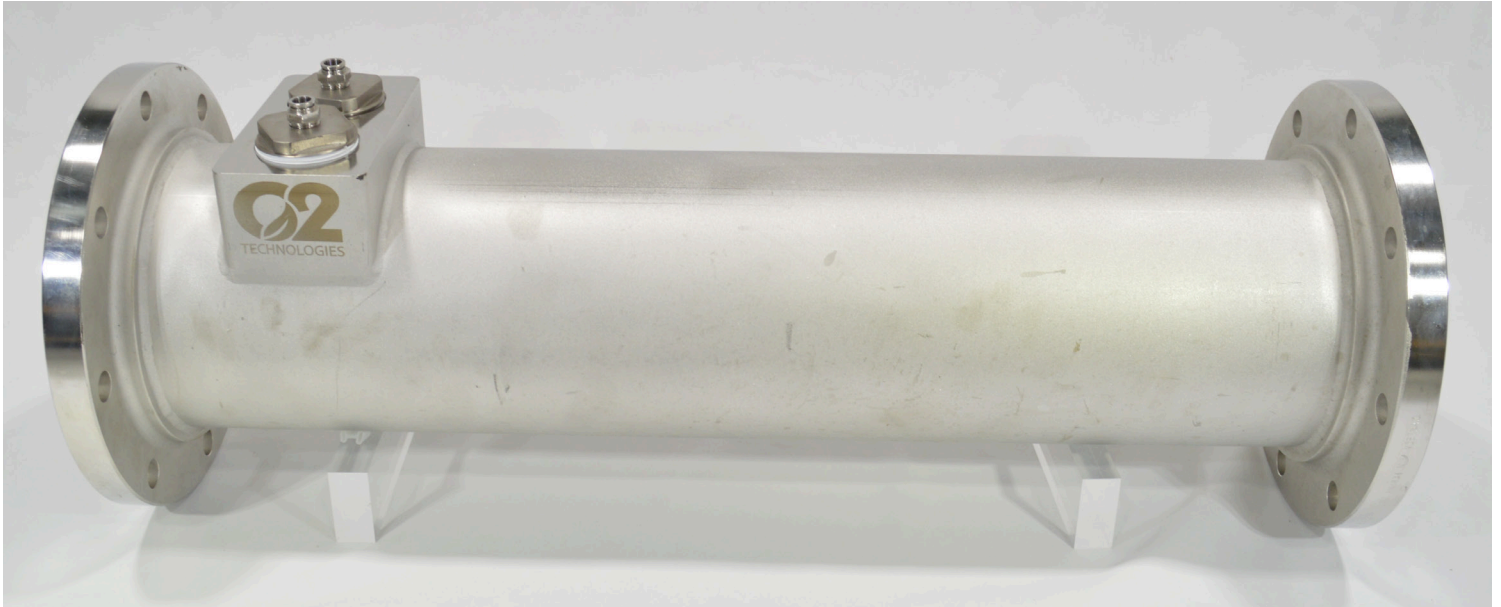

Nanobubble Generator

NBG-8" STAINLESS STEEL 316L



Features and Benefits

- Full Stainless Steel 316L Construction
- Compatible with ALL Gases including Ozone
- Easy to remove – 2 1/2" NPT - Dual Titanium 100 nm Injectors
- Proven nanobubble production in excess of 400 million/ml
- Average size of 100nm-sized bubbles
- Length 36.5" with 8" Class 150 8-Bolt Flange Connections
- Low gas pressure requirements
- Food Grade safe metals.
- High transfer efficiency >80% OTE
- Modular Design allowing for quick integration and installation

O2 Technologies Nanobubble generators are industry-leading in nanobubble generation, delivering unmatched efficiency. The full 316L stainless steel construction and modular connections allows for quick integration into systems while ensuring easy maintenance. The robust construction and high-quality materials provide reliable performance that you can count on.

Nanobubble Generator

NBG-8" STAINLESS STEEL 316L

TECHNICAL DETAILS

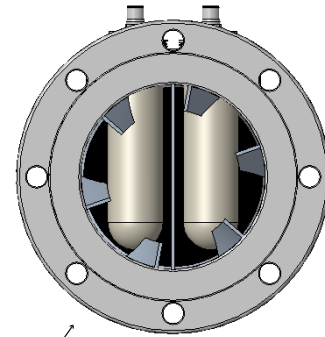
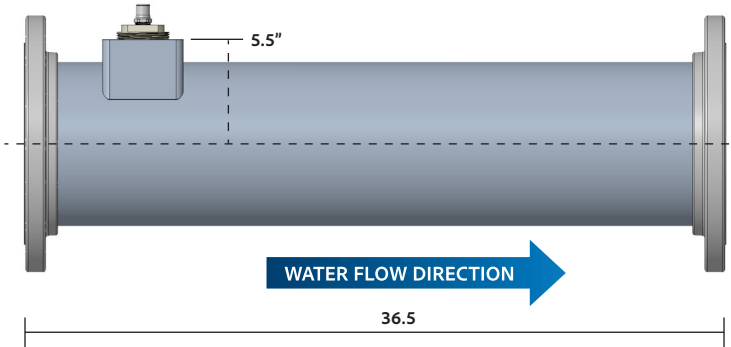

13.5" OD Class 150 Flange

GENERAL

Material	316L Stainless Steel
Injector	Titanium 100nm (removable)
Injector Interface	1/2" Push-to-connect Tube fitting to 1/4 NPT

SIZE AND WEIGHT

Pipe Flow Size	8"
Length	36.5"
Connection	8" Class 150 8 Bolt Flange

COTS PARTS EXAMPLES

8" Flange Blank	44695K167 – McMaster Carr
8" Flange Gasket	8516T244 – McMaster Carr

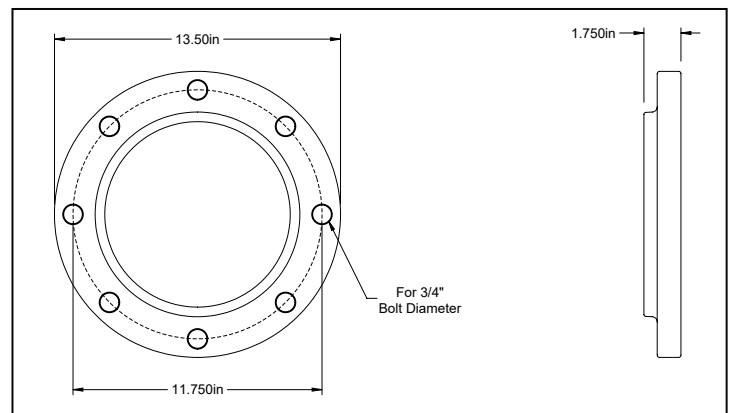
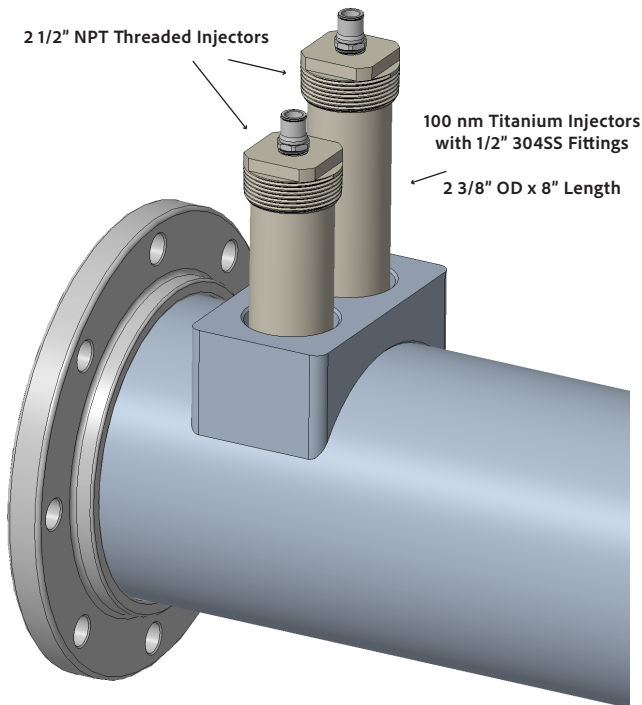



Nanobubble Generator

NBG-8" STAINLESS STEEL 316L

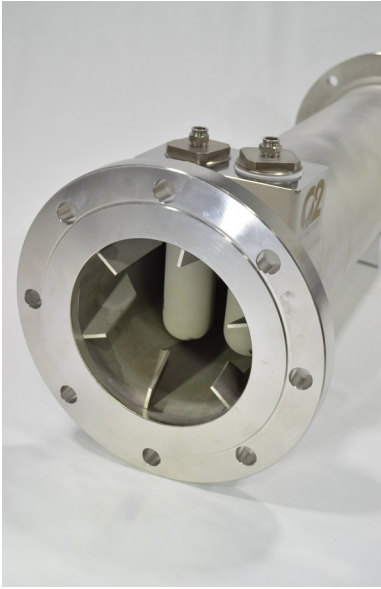

International/USA

sales@o2nanotech.com

www.o2nanotech.com