



Oxygen Nanobubble Platform

A SERIES - OUTDOOR-RATED



Features and Benefits

- Unique Patent Pending Design – Full Self-Contained Oxygen Nanobubble System
- Outdoor Rated Oxygen Concentrator supplies 90-93% O₂ at 10 LPM 20 psi
- Patent Pending Custom Class 1 Dryer System allows for continuous operation
- 1-month of 24/7 operations is equivalent to Qty 255 J Size Bottles
- Built in variable Speed Water Pump – 190 - 380 LPM
- Full Stainless Steel 316L Construction NBG with easy to remove 100 nm Injectors
- Proven nanobubble production in excess of 400 million/ml at average size of 100 nm
- Low Noise / Quiet Operation with Low Power Usage – Standard Plug
- Wash Down Capable + Corrosion Resistant Components

The A-Series Platform is a versatile oxygen delivery system engineered to support a wide range of agricultural, horticultural, turf, livestock, water treatment, and industrial processing applications. Designed for operational flexibility, the A-Series integrates easily into existing infrastructure and provides a scalable, low-pressure oxygenation solution that improves water quality, biological performance, and overall system efficiency.

The platform can be configured with 275-gallon, 330-gallon, 500-gallon, or 1,000-gallon tank systems, allowing operators to scale oxygenated water production based on operational demand. This modular configuration enables seamless integration into fertigation systems, spray rigs, livestock water systems, pond remediation programs, and production or processing environments.



Oxygen Nanobubble Platform

A SERIES - OUTDOOR-RATED

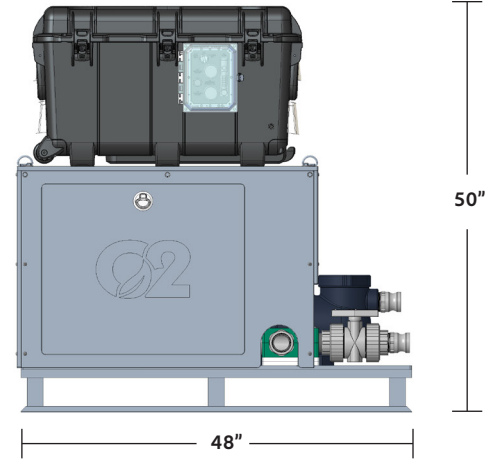
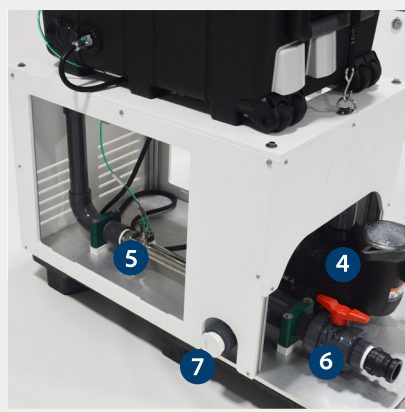
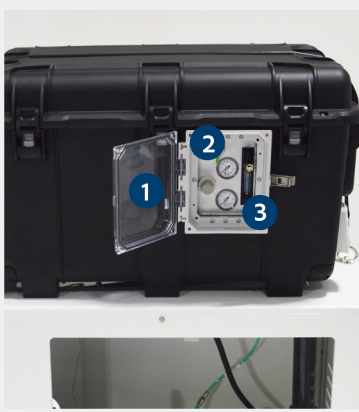

- 1 Simple Control Panel protected by Clear Polycarbonate Cover
- 2 Control Switch for Circulation Only Mode or Full System (Circulation and Oxygen)
- 3 Adjustable Flow Meter 0-10 LPM
- 4 1.5 HP Variable Speed Pump 190 - 380 LPM
- 5 2" Stainless Steel NBG
- 6 2" Schedule 80 PVC Ball Valve
- 7 2" Side Port for Water Transfer

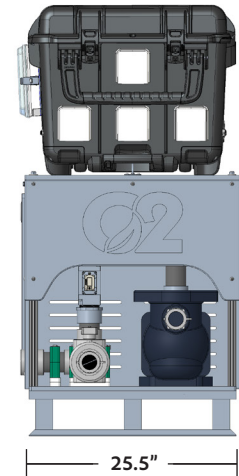

TECHNICAL DETAILS

- Removeable Standard Power Cord.
- Removable Latch Side panels for easy access.
- Exterior Dimensions: 25.5" x 48" x 50" height
- Optional Accessories:
 - Valve Skid for easy switching between different tanks
 - Remote Telemetry System – Oxygen Flow Rate, Water Flow Rate, Temperature, etc.



International/USA
sales@o2nanotech.com
www.o2nanotech.com